

Decorative Dress Spacer

The Decorative Dress Spacer is assembled between the door and the ENTR™ door unit.

Decorative Dress Spacers are available in 3 options:

1. Designed for 2-7 mm of space
2. Designed for 9-13 mm of space
3. Designed for 14-19 mm of space

Assembly instructions:

1. Measure cylinder protrusion (L) from door surface (Fig 1):
 - For cylinder protrusion of 2-7 mm use option 1
 - For cylinder protrusion of 9-13 mm use option 2
 - For cylinder protrusion of 14-19 mm use option 3
2. Remove door unit
3. Remove inner cover/rosette
4. Assemble the Decorative Dress Spacer matching the space measured. In order to adjust the spacers to the correct space required (options 2 or 3) break the matching projecting part in the spacer.

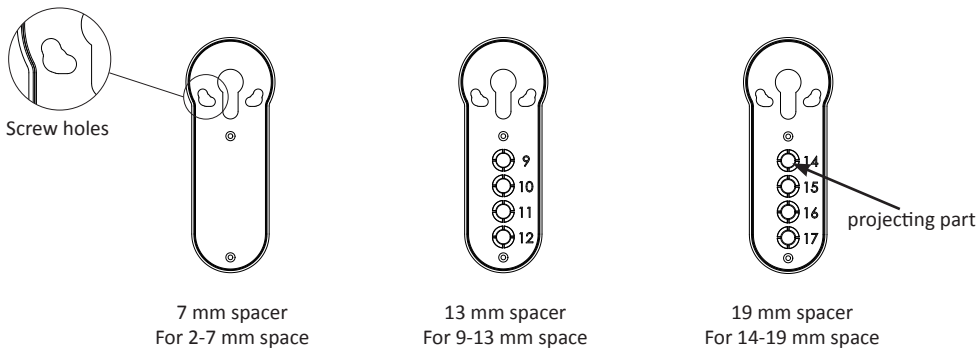
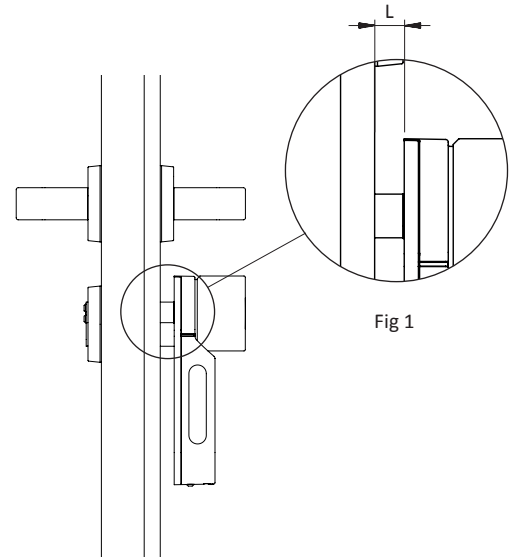

- Attach the Decorative Dress Spacer to the door using screws or use a double sided glue.
- Screw holes in the Decorative Dress Spacer are located according to various DIN standards (see illustration).

